



FOR IMMEDIATE RELEASE:

ENGINEERED FORMWORK SYSTEM UTILIZES CUSTOM FRP ARCH/COLUMN FORMS TO CAST UNIQUE FAÇADE FOR USMA/WEST POINT'S NEW \$59 MILLION LIBRARY EXPANSION

HISTORIC CHALLENGE:

Given the deep heritage of United States Military Academy (USMA) in West Point (West Point, NY) as the nation's oldest military post any changing of the guard is significant; case in point the new estimated \$59 million/148,000 square foot USMA Library and Learning Center. The new facility, identified as Jefferson Hall Library (JHL), marks the first new academic building to appear in the Academy's central Cadet Academic Zone since 1972 and is scheduled for occupancy in March 2008.

Because the facility is in the heart of West Point's history district all design and construction principles (selected by New York District Army Corps of Engineers and the United States Military Academy) faced the challenge of achieving a state-of-the-art structural facility which could support a technological mission of training officers in an information-age army while preserving its historic milieu. To accentuate its storied past, the expansion (which will occupy a prominent space directly opposite the present library: Est. 1964) will utilize intricate FRP (fiberglass reinforced plastic) formwork to create exterior concrete aesthetic features such as unique archways and columns.

ARCHITECTURAL/AESTHETIC DESIGN:

In 2005, the Army Corps of Engineers awarded the design contract to STV Inc. (New York, NY); one of the nation's top engineering, architectural, planning, environmental and construction management firms. Included in the STV design was a unique arch-and-column facade as a centerpiece to adorn the facilities' main entranceway.



"West Point presented a diverse combination of site issues and user objectives; including the entranceway design which had to aesthetically project both the history and future of the Academy," said STV project manager Price Jepsen. The final entranceway design was comprised of two vertical column arch forms spanning twenty five (25) feet from column-to-column and adorned with intricate cloverleaf-shaped cast impressions/reliefs. In the final design configuration, the columns structurally had to support some building loads; with the arches supporting their own weight.



CUSTOM FRP FORMWORK SYSTEM:

With the designs approved, General Contractor J. Kokolakis Contracting, Inc. (Rocky Point NY) awarded Roger & Sons Concrete Inc. (LaGrangeville, NY) the concrete contract whose scope included fabricating, assembling the formwork, installing the reinforcing, placing and finishing all concrete. Roger & Sons Vice President, Manny Rodriques then enlisted their formwork subcontractor, Ceco Concrete Construction (Gladstone, Missouri) to secure custom suppliers for the complex entranceway formwork system. Ceco Senior Project Manager Rick Rohrer had experience with a U.S. manufacturer who could achieve the unique configuration demands; Molded Fiber Glass Construction Products (MFG: Independence, KS) who manufactured a complete range of standard and custom one-piece fiberglass reinforced plastic (FRP) forms.

According to Rohrer, “Because these were special items involving several shapes and sizes; requiring separate molds & tooling for each piece, wood-based forms were not a realistic economic or durable option. We requested a bid from MFG from our initial sketches and they researched and prepared engineering shop drawings that successfully met the design and performance challenges.”

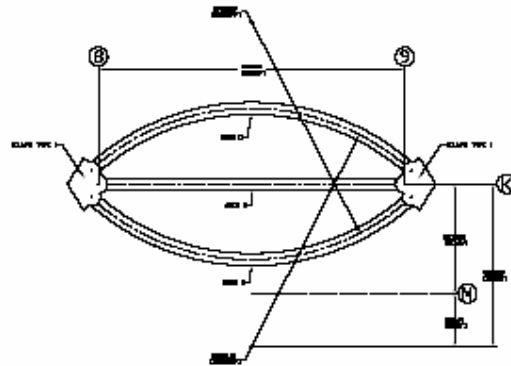

Eric Brace, MFG Engineering Manager stated, “This was a very unique project from a design and engineering standpoint as the arch forms were at a compound radius, or curved at two angles, so CNC (Computer Numerical Control) cutting would be required to make certain the correct dimensions and tolerances were achieved from column-to-column.” Additionally, because the design aesthetic mandated a smooth, shiny surface, MFG Construction’s custom 220 grit sand & buff composite forms could produce a shiny result with a smooth/clean finish (leaving no rebar seams or bug holes) to the columns; an essential deliverable to the architectural vision specifications.



Having been awarded the bid in March 2006, the MFG Phase I (entranceway) production of the two-phase Jefferson Hall Library custom architectural formwork project. MFG custom-fabricated two (2) columns and three (3) arches spanning 16 total pieces. Once completed, the individual parts were assembled at MFG Construction's plant to ensure the compound radius design would fit accurately. With this achieved, the forms were then shipped separately to the West Point jobsite on July 17th 2006 for the installations' assembly, rebar and concrete pour completion.

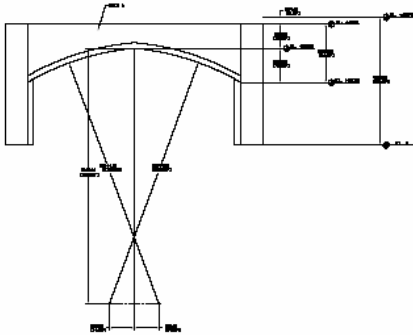

REBAR & CONCRETE: SPECS & ASSEMBLY

With the forms now shipped and assembled onsite, Roger & Sons Concrete Inc. began assembly of the rebar reinforcing in preparation for a concrete pour of approximately 2,239 cy (cubic yards) for the exposed areas of the projects six completed floors. According to Roger & Sons jobsite superintendent Jack Vecchiarelli, "The rebar assembly is a unique non-standard installation challenge because the design doesn't follow a normal configuration. The geometry of the structure is computed on a sloping arch radius so additional bars will be needed throughout the installation to support the horizontal and vertical arches."



In addition to the additional rebar required because of the design's bends and lapping, even more was mandated for the military's allowance for shock absorbance protection in the event of a potential terrorist explosion. Approximately 1,937,000 pounds of fabricated standard Grade 420 black steel reinforcing bars will be utilized throughout the buildings six completed floors.





With the engineered formwork system now assembled and rebar installed, concrete pouring began using a grey colored standard concrete. Initial test pours utilizing the standard concrete produced a honeycomb effect (patches around the beams and air bubbles) contrary to the smooth, shiny surface finish desired. A self-compacting concrete was then chosen as an optimal solution because it contained a chemical additive that required no additional vibration; usually required to get peripheral air out of concrete, which would ensure a uniform finish.

Vecchiarelli concluded, “Given the unique configuration of the main entrance’s arch-and-column formwork system, the self-compacting concrete allowed more flow-ability in tight areas and sharp corners; thus minimizing the placement time. The result is a clean, sharp finish.” Approximately 20 cy of the self-compacting concrete was poured across the buildings archway, stair, column and beam areas (including form liners).



After the pour completion the formwork removal takes place on the entranceway. The systems’ intricate design involves removal of sixteen total pieces that will need to be unbolted and ties broken off; with some parts coming off easier than others. Additionally, the expansive size and bulk of the formwork will require fork-and-scissor lifts to safely lower them down.

CONCLUSION:

Phase I (Main Entranceway) formwork will be completed October, 2006, with Phase II (2nd-thru-6th floors) ensuing with a targeted January 2007 finish date. Phase II formwork entails **more exposed exterior columns and arches for the rotunda areas on each level**; similar in finish with a more special reading area arch-look; predominant in existing campus-wide buildings. **Additionally, 75% of the interior concrete surfaces are exposed to view and have aesthetic features which require great attention to the form system and placement of concrete; to assure a uniform color and finish.**

According to MFG’s Eric Brace, “The complexity and required aesthetic appearance of this particular structure were an ideal application for the functional beauty of cast-in-place FRP concrete formwork. Because of the unique characteristics of fiberglass, it can be formed and molded for use in the creation of functional, yet aesthetically appealing, architectural designs.”



CORPORATE PROFILE:

MFG Construction Products Company, formed in 1962 and a charter member of the World of Concrete, manufactures a complete range of one-piece round column forms (RCFs), dome and pan forms for one-way and two-way joist slab floors, and customer forms for cast-in-place concrete construction applications. Made of fiberglass-reinforced thermo-set composites, MFG concrete forms can significantly reduce finishing costs and are fully re-usable.

Comprised of twelve key entities in eight states Molded Fiber Glass Companies (EST: 1948) has been a pioneering force in optimizing resins and fiber reinforced polymer (FRP) materials and continues to build strength through focused diversity in providing superior composite material solutions worldwide.

Author:

Gerry Bender/General Manager: MFG Construction Products
620-331-7366 / gbender@moldedfiberglass.com

Editorial / Photo Contact:

Ray Farrar / President: Method Media LLC
216-861-0862 / rayf@methmedia.net